



**Department of Agriculture**  
**Regional Field Office No. 5**  
San Agustin, Pili, Camarines Sur

**REQUEST TO SUBMIT QUOTATION OR PROPOSAL FOR LABOR AND MATERIALS FOR THE IMPROVEMENT OF ELECTRICAL SYSTEM OF PILI PROCESSING FACILITY UNDER 2023 HVCDP AT APPROVED BUDGET FOR THE CONTRACT AMOUNTING TO TWO HUNDRED FIFTY-FIVE THOUSAND PESOS (PHP 255,000.00) PURSUANT TO ALTERNATIVE METHOD OF PROCUREMENT SPECIFICALLY NEGOTIATED PROCUREMENT-SMALL VALUE PROCUREMENT UNDER SECTION 53.9 UNDER RA 9184 AND ITS REVISED IRR.**

The Department of Agriculture Regional Field Unit No. 5 (DA RFO 5), San Agustin, Pili, Camarines Sur is inviting interested suppliers to submit complete bid proposal for the ff:

	<b>Particulars</b>	<b>ABC</b>
	Electrical System of Pili Processing Facility	255,000.00

The agency intends to apply the amount of **TWO HUNDRED FIFTY-FIVE THOUSAND PESOS (PHP 255,000.00)** as the Approved Budget for the Contract.

As per approved Purchase Request and considering the nature of requisition being not more than One Million Pesos (Php1,000,000.00) and in order to fast-track the implementation of the program, this procurement is facilitated thru Negotiated Procurement-Small Value Procurement under Section 53.9 of RA 9184 and its Revised IRR.

As such: **MTJ CONSTRUCTION AND SUPPLY**, Cong. J. Nuyda Ave. Brgy 4, Camalig, Albay; **HDB CONSTRUCTION**, Villa Sorobella Subdivision, Concepcion Grande, Naga City; **MAGDA CONSTRUCTION AND SUPPLY**, Legazpi City, Albay and all interested bidders are hereby requested to submit the following documents:

1. Mayor's Permit (Updated or At least proof of renewal)
2. DTI/SEC/CDA Registration
3. PhilGEPS Registration
4. Omnibus Sworn Statement
5. BIR Registration
6. PCAB License

The bidders are required to pay the non-refundable amount **Five Hundred Pesos (Php 500.00)** for bid documents to the Cashier's Office, DA RFO-5, Pili, Camarines Sur. **All submitted documents must be in duplicate (ORIGINAL AND COPY 1), all copies must be A4 size bond paper, marked with ear tabs or side-end to identify the page components and shall be properly addressed to the BAC Chairperson.** otherwise, bids will be automatically rejected on the ground of non-compliance with the prescribed bid requirements.

**Sealed Bid must be received by BAC Secretariat not later than 9:00 in the morning of 30 June 2023** at the BAC Office, DA RFO 5, San Agustin, Pili Camarines Sur. Late bids shall not be accepted. The opening of Proposal shall be at 10:00 AM onwards at 3rd Floor Operation Building, DA RFO-5, San Agustin, Pili, Camarines Sur.

Let this Invitation be posted pursuant to RA 9184 and its IRR. For more information, please see or contact BAC Secretariat Office, via email [bacrfo5@gmail.com](mailto:bacrfo5@gmail.com).

June 26, 2023 San Agustin, Pili, Camarines Sur.

**LORENZO L. ALVINA**  
Chief, Integrated Laboratory Division  
BAC Chairperson



**Department of Agriculture**  
**Regional Field Office No. 5**  
San Agustin, Pili, Camarines Sur

**BID FORM**

Date : \_\_\_\_\_  
Project Identification No. : \_\_\_\_\_

To: *[name and address of Procuring Entity]*

Having examined the Philippine Bidding Documents (PBDs) including the Supplemental or Bid Bulletin Numbers *[insert numbers]*, the receipt of which is hereby duly acknowledged, we, the undersigned, declare that:

- a. We have no reservation to the PBDs, including the Supplemental or Bid Bulletins, for the Procurement Project: *[insert name of contract]*;
- b. We offer to execute the Works for this Contract in accordance with the PBDs;
- c. The total price of our Bid in words and figures, excluding any discounts offered below is: *[insert information]*;
- d. The discounts offered and the methodology for their application are: *[insert information]*;
- e. The total bid price includes the cost of all taxes, such as, but not limited to: *[specify the applicable taxes, e.g. (i) value added tax (VAT), (ii) income tax, (iii) local taxes, and (iv) other fiscal levies and duties]*, which are itemized herein and reflected in the detailed estimates,
- f. Our Bid shall be valid within a period stated in the PBDs, and it shall remain binding upon us at any time before the expiration of that period;
- g. If our Bid is accepted, we commit to obtain a Performance Security in the amount of *[insert percentage amount]* percent of the Contract Price for the due performance of the Contract, or a Performance Securing Declaration in lieu of the allowable forms of Performance Security, subject to the terms and conditions of issued GPPB guidelines<sup>1</sup> for this purpose;
- h. We are not participating, as Bidders, in more than one Bid in this bidding process, other than alternative offers in accordance with the Bidding Documents;
- i. We understand that this Bid, together with your written acceptance thereof included in your notification of award, shall constitute a binding contract between us, until a formal Contract is prepared and executed; and
- j. We understand that you are not bound to accept the Lowest Calculated Bid or any other Bid that you may receive.
- k. We likewise certify/confirm that the undersigned, is the duly authorized representative of the bidder, and granted full power and authority to do, execute and perform any and all acts necessary to participate, submit the bid, and to sign and execute the ensuing contract for the *[Name of Project]* of the *[Name of the Procuring Entity]*.
- l. We acknowledge that failure to sign each and every page of this Bid Form, including the Bill of Quantities, shall be a ground for the rejection of our bid.

Name: \_\_\_\_\_

Legal Capacity: \_\_\_\_\_

Signature: \_\_\_\_\_

Duly authorized to sign the Bid for and behalf of: \_\_\_\_\_

Date: \_\_\_\_\_

Omnibus Sworn Statement (Revised)  
[shall be submitted with the Bid]

<sup>1</sup> currently based on GPPB Resolution No. 09-2020



**Department of Agriculture**  
**Regional Field Office No. 5**  
San Agustin, Pili, Camarines Sur

REPUBLIC OF THE PHILIPPINES)  
CITY/MUNICIPALITY OF \_\_\_\_\_) S.S.

**AFFIDAVIT**

I, [Name of Affiant], of legal age, [Civil Status], [Nationality], and residing at [Address of Affiant], after having been duly sworn in accordance with law, do hereby depose and state that:

1. [Select one, delete the other:]

[If a sole proprietorship:] I am the sole proprietor or authorized representative of [Name of Bidder] with office address at [address of Bidder];

[If a partnership, corporation, cooperative, or joint venture:] I am the duly authorized and designated representative of [Name of Bidder] with office address at [address of Bidder];

2. [Select one, delete the other:]

[If a sole proprietorship:] As the owner and sole proprietor, or authorized representative of [Name of Bidder], I have full power and authority to do, execute and perform any and all acts necessary to participate, submit the bid, and to sign and execute the ensuing contract for [Name of the Project] of the [Name of the Procuring Entity], as shown in the attached duly notarized Special Power of Attorney;

[If a partnership, corporation, cooperative, or joint venture:] I am granted full power and authority to do, execute and perform any and all acts necessary to participate, submit the bid, and to sign and execute the ensuing contract for [Name of the Project] of the [Name of the Procuring Entity], as shown in the attached [state title of attached document showing proof of authorization (e.g., duly notarized Secretary's Certificate, Board/Partnership Resolution, or Special Power of Attorney, whichever is applicable)];

3. [Name of Bidder] is not "blacklisted" or barred from bidding by the Government of the

Philippines or any of its agencies, offices, corporations, or Local Government Units, foreign government/foreign or international financing institution whose blacklisting rules have been recognized by the Government Procurement Policy Board, by itself or by relation, membership, association, affiliation, or controlling interest with another blacklisted person or entity as defined and provided for in the Uniform Guidelines on Blacklisting;

4. Each of the documents submitted in satisfaction of the bidding requirements is an authentic copy of the original, complete, and all statements and information provided therein are true and correct;

5. [Name of Bidder] is authorizing the Head of the Procuring Entity or its duly authorized representative(s) to verify all the documents submitted;

6. [Select one, delete the rest:]

[If a sole proprietorship:] The owner or sole proprietor is not related to the Head of the Procuring Entity, members of the Bids and Awards Committee (BAC), the Technical



**Department of Agriculture**  
**Regional Field Office No. 5**  
San Agustin, Pili, Camarines Sur

GPPB Resolution No. 16-2020, dated 16 September 2020

Working Group, and the BAC Secretariat, the head of the Project Management Office or the end-user unit, and the project consultants by consanguinity or affinity up to the third civil degree; [If a partnership or cooperative:] None of the officers and members of [Name of Bidder] is related to the Head of the Procuring Entity, members of the Bids and Awards Committee (BAC), the Technical Working Group, and the BAC Secretariat, the head of the Project Management Office or the end-user unit, and the project consultants by consanguinity or affinity up to the third civil degree;

[If a corporation or joint venture:] None of the officers, directors, and controlling stockholders of [Name of Bidder] is related to the Head of the Procuring Entity, members of the Bids and Awards Committee (BAC), the Technical Working Group, and the BAC Secretariat, the head of the Project Management Office or the end-user unit, and the project consultants by consanguinity or affinity up to the third civil degree;

7. [Name of Bidder] complies with existing labor laws and standards; and
8. [Name of Bidder] is aware of and has undertaken the responsibilities as a Bidder in compliance with the Philippine Bidding Documents, which includes:
  - a. Carefully examining all of the Bidding Documents;
  - b. Acknowledging all conditions, local or otherwise, affecting the implementation of the Contract;
  - c. Making an estimate of the facilities available and needed for the contract to be bid, if any; and
  - d. Inquiring or securing Supplemental/Bid Bulletin(s) issued for the [Name of the Project].
9. [Name of Bidder] did not give or pay directly or indirectly, any commission, amount, fee, or any form of consideration, pecuniary or otherwise, to any person or official, personnel or representative of the government in relation to any procurement project or activity.
10. In case advance payment was made or given, failure to perform or deliver any of the obligations and undertakings in the contract shall be sufficient grounds to constitute criminal liability for Swindling (Estafa) or the commission of fraud with unfaithfulness or abuse of confidence through misappropriating or converting any payment received by a person or entity under an obligation involving the duty to deliver certain goods or services, to the prejudice of the public and the government of the Philippines pursuant to Article 315 of Act No. 3815 s. 1930, as amended, or the Revised Penal Code.

IN WITNESS WHEREOF, I have hereunto set my hand this \_\_ day of \_\_, 20\_\_ at\_\_\_\_, Philippines.

[Insert NAME OF BIDDER OR ITS AUTHORIZED REPRESENTATIVE]

[Insert signatory's legal capacity]

Affiant

[Jurat]

[Format shall be based on the latest Rules on Notarial Practice]



**Department of Agriculture**  
**Regional Field Office No. 5**  
San Agustin, Pili, Camarines Sur

GPPB Resolution No. 16-2020, dated 16 September 2020



**Department of Agriculture  
Regional Field Office No. 5  
San Agustin, Pili, Camarines Sur**

**BILL OF QUANTITIES AND COST PROPOSAL**

NAME OF PROJECT:  IMPROVEMENT OF ELECTRICAL SYSTEM OF PILI PROCESSING FACILITY		Appropriation (Php) P 255,000.00 Source of Funds For Funding Issued Obligated Authority Mode of Implementation Released Calendar Days to Complete 20 C.D	
Location: BACON DISTRICT, SORSOGON PROJECT CATEGORY: INFRASTRUCTURE		Starting Date	
PROJECT DESCRIPTION/SCOPE OF WORK:			
MINIMUM EQUIPMENT REQUIREMENT		TECHNICAL PERSONNEL REQUIRED	
Description	No.	Description	No.
Minor Tools			
Item	Description	Unit	Quantity
I	ELECTRICAL WORKS	lot	1.00
II	REMOVAL/CONCRETE WORKS	lot	1.00
TOTAL PROJECT COST			
		Unit Cost (PhP)	Total Amount (PhP)

*Note: All taxes, contractor's profit and hauling cost are included in unit cost per item.*

\_\_\_\_\_  
NAME AND SIGNATURE OF BIDDER



### POWER LAYOUT

SCALE 1:50 M

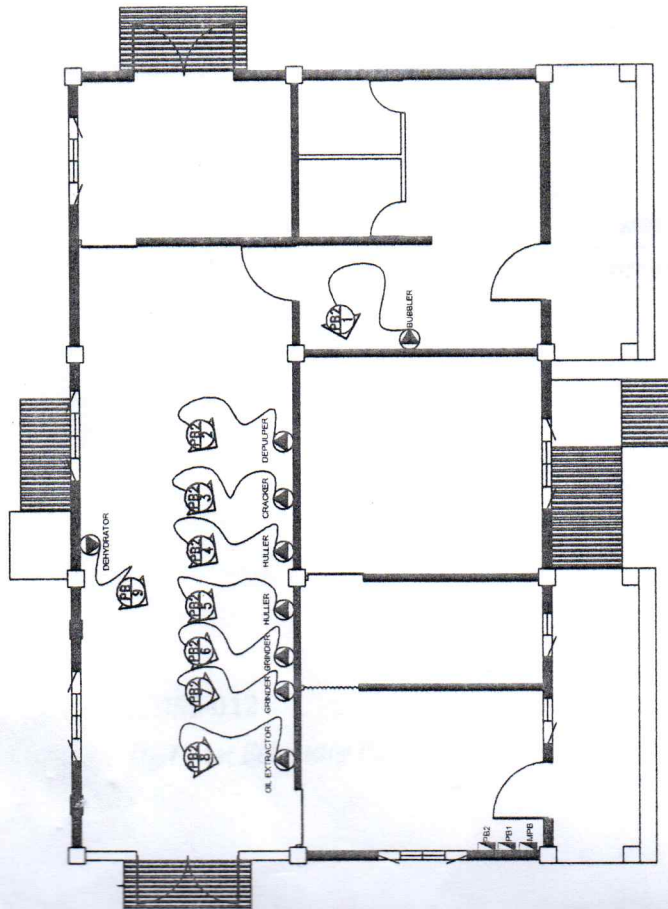

### LOAD COMPUTATION

SERVICE CONDUCTOR FOR PB2

$$IT = PB2 + 25 \times LM$$

230

$$IT = 21,390 + .25 \times 3910$$

230

$$IT = 97.25 \text{ AMPS}$$

USE: 2 - 38MM<sup>2</sup> THHN + 1-14MM<sup>2</sup> THHN (G) IN 32MM dia R5C0/PVC  
 USE: 2P - 150AT MCCB BOLT-ON TYPE,  
 FOR MAIN FEEDER CONDUCTOR

FOR MAIN FEEDER CONDUCTOR

$$I = \frac{PB1(\text{EXISTING PB}) + PB2 + 0.25(L.M.)}{230}$$

230

$$I = \frac{10070 + 21390 + 0.25(3910)}{230}$$

230

$$I = 141 \text{ AMPS}$$

USE 2C - 60MM<sup>2</sup> THHN CU WIRE

1C - 22 MM<sup>2</sup> THW CU WIRE (G)

IN 53MM DIA UPVGR5C CONDUIT

USE 200AT, 2P, 240V MCCB BOLT ON TYPE

FOR TRANSFORMER, KVA RATING

$$KVA = 32.2 \text{ KVA}$$

USE 1 - 37.5KVA SINGLE PHASE DISTRIBUTION TRANSFORMER

FUSE LINK RATING

$$If = 37.5 \text{ KVA}$$

$$13.2 \text{ KV}$$

$$If = 2.64$$

USE 1 - 3A FUSE LINK

### SERVICE ENTRANCE

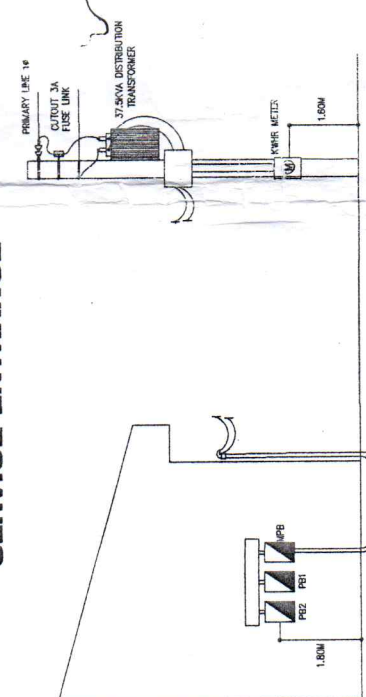

### RISER DIAGRAM

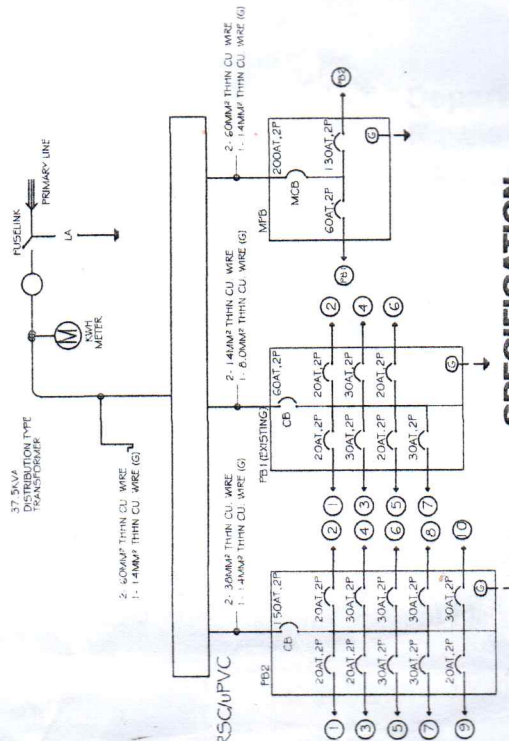

### SPECIFICATION

1. THE ELECTRICAL WORKS SHALL BE DONE IN ACCORDANCE WITH THE RULES AND REGULATIONS OF THE LATEST EDITION OF THE PHILIPPINE ELECTRICAL CODE APPLICABLE ORDINANCE OF THE LOCAL GOVERNMENT AND THE LOCAL POWER COMPANY.
2. WIRING SHALL BE INSTALLED IN RIGID STEEL CONDUIT AND PVC EMBEDDED IN CONCRETE SLAB FLOOR OR UNDERGROUND AND WALLS
3. EXPOSED WIRING SHALL BE PARALLEL OR PERPENDICULAR TO THE BUILDING LINE WITH APPROVED TYPE OF CONDUIT SUPPORT
4. ALL MATERIALS TO BE USED SHALL BE BRAND NEW AND OF THE APPROVED TYPE FOR THE PURPOSE LOCATION
5. ALL ELECTRICAL EQUIPMENT SUCH AS SAFETY DISCONNECT, PANEL BOARDS ETC., SHALL BE PROVIDED WITH GROUNDINGS
6. PROVIDE ADEQUATE GROUNDING FOR MOTOR FRAMES
7. SERVICE ENTRANCE SHALL BE 1Ø, 220V, 60HZ
8. ALL ELECTRICAL WORK HEREIN SHALL BE SUPERVISED BY A DULY LICENSED ELECTRICAL ENGINEER OR MASTER ELECTRICIAN

### LEGEND

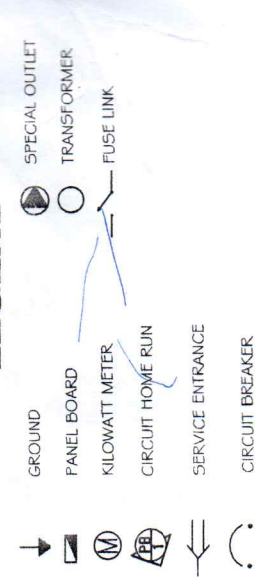

### SCHEDULE OF LOADS

CCT. NO.	DESCRIPTION	QTY.	NUMBER OF			VA	AMPS	WIRE SIZE	CONDUIT	CIRCUIT BREAKER
			S1	S2	S3					
1	BUBBLER	1	230	1840	8.00	2C-5.5mm <sup>2</sup> THHN CU wire 1C-3.5mm <sup>2</sup> THHN CU wire	20mm <sup>Ø</sup> uPVC pipe	200AT, 2P		
2	DEPULPER	1	230	1840	8.00	2C-5.5mm <sup>2</sup> THHN CU wire 1C-3.5mm <sup>2</sup> THHN CU wire	20mm <sup>Ø</sup> uPVC pipe	200AT, 2P		
3	CRACKER	1	230	1840	8.00	2C-5.5mm <sup>2</sup> THHN CU wire 1C-3.5mm <sup>2</sup> THHN CU wire	20mm <sup>Ø</sup> uPVC pipe	200AT, 2P		
4	HULLER	1	230	2760	12.00	2C-5.5mm <sup>2</sup> THHN CU wire 1C-3.5mm <sup>2</sup> THHN CU wire	20mm <sup>Ø</sup> uPVC pipe	300AT, 2P		
5	HULLER	1	230	2760	12.00	2C-5.5mm <sup>2</sup> THHN CU wire 1C-3.5mm <sup>2</sup> THHN CU wire	20mm <sup>Ø</sup> uPVC pipe	300AT, 2P		
6	GRINDER	1	230	2900	10.00	2C-5.5mm <sup>2</sup> THHN CU wire 1C-3.5mm <sup>2</sup> THHN CU wire	20mm <sup>Ø</sup> uPVC pipe	300AT, 2P		
7	GRINDER	1	230	2900	10.00	2C-5.5mm <sup>2</sup> THHN CU wire 1C-3.5mm <sup>2</sup> THHN CU wire	20mm <sup>Ø</sup> uPVC pipe	300AT, 2P		
8	OIL EXTRACTOR	1	230	3010	17.00	2C-5.5mm <sup>2</sup> THHN CU wire 1C-3.5mm <sup>2</sup> THHN CU wire	20mm <sup>Ø</sup> uPVC pipe	300AT, 2P		
9	DEHIDRATOR	1	230	1840	8.00	2C-5.5mm <sup>2</sup> THHN CU wire 1C-3.5mm <sup>2</sup> THHN CU wire	20mm <sup>Ø</sup> uPVC pipe	200AT, 2P		
10	SPARE	1	230					300AT, 2P		
	TOTAL	10	230	21390	93.00					

Prepared by: *[Signature]* Checked by: *[Signature]* Recommended Approval: *[Signature]* Approved by: *[Signature]*

NAME OF PROJECT: IMPROVEMENT OF ELECTRICAL SYSTEM OF PLU PROCESSING FACILITY  
 LOCATION: BACON DISTRICT, SORSOGON

CAD BY: *[Signature]* DRAWN: *[Signature]* DATE: *[Signature]* SHEET NO.: *[Signature]*

REPUBLIC OF THE PHILIPPINES  
 DEPARTMENT OF AGRICULTURE  
 REGIONAL FIELD UNIT NO. 5