

[SVP#49-2024-MASBATE] REQUEST TO SUBMIT QUOTATION OR PROPOSAL FOR REPAIR AND IMPROVEMENT OF MCLD WATER SYSTEM FACILITY AT ROS-MASBATE UNDER OTHER R&D 2024 WITH AN APPROVED BUDGET FOR THE CONTRACT (ABC) IN THE AMOUNT OF THREE HUNDRED FIFTY THOUSAND PESOS (₱350,000.00) PURSUANT TO ALTERNATIVE METHOD OF PROCUREMENT SPECIFICALLY NEGOTIATED PROCUREMENT-SMALLVALUE PROCUREMENT UNDER SECTION 53.9 UNDER RA 9184 AND ITS REVISED IRR.

The Department of Agriculture Regional Field Office No. 5 (DA RFO 5), San Agustin, Pili, Camarines Sur is inviting interested contractors to submit complete bid quotation for the:

QTY.	UNIT	PARTICULAR	UNIT PRICE	TOTAL ABC
		REPAIR AND IMPROVEMENT OF MCLD WATER SYSTEM FACILITY AT ROS-MASBATE UNDER OTHER R&D 2024 <ul style="list-style-type: none"> • Specification should conform to detailed Engineering Design. • Project Duration: Based on BOQ15 CD 	350,000.00	₱350,000.00
TOTAL				₱350,000.00

For **REPAIR AND IMPROVEMENT OF MCLD WATER SYSTEM FACILITY AT ROS-MASBATE UNDER OTHER R&D 2024**.The agency intends to apply the amount of **Three Hundred Fifty Thousand Pesos** only (Php350,000.00) as the Approved Budget for the Contract.

As per approved Purchase Request and considering the nature of requisition being not more than One Million Pesos (Php1,000,000.00) and in order to fast-track the implementation of the program, this procurement is facilitated thru Negotiated Procurement-Small Value Procurement under Section 53.9 of RA 9184 and its Revised IRR.

As such: **HDB CONSTRUCTION** Concepcion Grande Naga City; **LANOBLE CONSTRUCTION, Zone 1, Boclod, San Jose, Cam. Sur**; **MTJ CONSTRUCTION & SUPPLY**, Barangay 4 (Pob.), Camalig, Albay and all interested bidders are hereby requested to submit the following documents:

1. Mayors Permit (updated or proof of renewal)
2. DTI/SEC/CDA Registration
3. PhilGEPS Registration
4. Omnibus Sworn Statement
5. BIR Registration
7. PCAB Licence

The bidders are required to pay the non-refundable amount **Five Hundred Pesos (₱500.00)** for bid documents to the Cashier's Office, DA RFO-5, Pili, Camarines Sur. **All submitted documents must be in duplicate (ORIGINAL AND COPY 1), all copies must be marked with ear tabs or side-end to identify the page components and shall be properly addressed to the BAC Chairperson,** otherwise, bids will be automatically rejected on the ground of non-compliance with the prescribed bid requirements.

Sealed Bid must be duly received by BAC Secretariat through manual submission not later than 9:00AM in the morning of June 14, 2024 at the BAC Office, DA RFO 5, San Agustin, Pili Camarines Sur. Late bids shall not be accepted. The opening of Proposal shall be at **10:00AM** onwards at 3rd Floor Operation Building, DA RFO-5, San Agustin, Pili, Camarines Sur.



Let this Invitation be posted pursuant to RA 9184 and its IRR. For further information, please refer to BAC Secretariat Office, DA RFO 5, San Agustin, Pili Camarines Sur or via email bacrfo5@gmail.com

June 7, 2024 San Agustin, Pili, Camarines Sur.

LORENZO L. ALVINA
OIC, RTD for Research and Regulation
BAC Chairperson





BID FORM

Date: _____

To: **DEPARTMENT OF AGRICULTURE**
Address: San Agustin, Pili, Camarines Sur

We, the undersigned, declare that:

- (a) We have examined and have no reservation to the Bidding Documents, including Addenda, for the Contract _____
- (b) We offer to execute the Works for this Contract in accordance with the Bid and Bid Data Sheet, General and Special Conditions of Contract accompanying this Bid;

The total price of our Bid, excluding any discounts offered below is: _____

The discounts offered and the methodology for their application are;

- (c) Our Bid shall be valid for a period of 120 days from the date fixed for the Bid submission deadline in accordance with the Bidding Documents, and it shall remain binding upon us and may be accepted at any time before the expiration of that period;
- (d) If our Bid is accepted, we commit to obtain a Performance Security in the amount of 30 percent of the Contract Price for the due performance of the Contract;
- (e) Our firm, including any subcontractors or suppliers for any part of the Contract, have nationalities from the following eligible countries: _____;
- (f) We are not participating, as Bidders, in more than one Bid in this bidding process, other than alternative offers in accordance with the Bidding Documents;
- (g) Our firm, its affiliates or subsidiaries, including any subcontractors or suppliers for any part of the Contract, has not been declared ineligible by the Funding Source;
- (h) We understand that this Bid, together with your written acceptance thereof included in your notification of award, shall constitute a binding contract between us, until a formal Contract is prepared and executed; and
- (i) We understand that you are not bound to accept the Lowest Calculated Bid or any other Bid that you may receive.
- (j) **We likewise certify/confirm that the undersigned, is the duly authorized representative of the bidder, and granted full power and authority to do, execute and perform any and all acts necessary to participate, submit the bid, and to sign and execute the ensuing contract for the _____ of the DEPARTMENT OF AGRICULTURE.**
- (k) **We acknowledge that failure to sign each and every page of this Bid Form, including the Bill of Quantities, shall be a ground for the rejection of our bid.**

Name: _____

In the capacity of: _____

Signed: _____

Duly authorized to sign the Bid for and on behalf of: _____



Omnibus Sworn Statement (Revised) *[shall be submitted with the Bid]*

REPUBLIC OF THE PHILIPPINES)
CITY/MUNICIPALITY OF _____) S.S.

AFFIDAVIT

I, [Name of Affiant], of legal age, [Civil Status], [Nationality], and residing at [Address of Affiant], after having been duly sworn in accordance with law, do hereby depose and state that:

1. *[Select one, delete the other:]*

[If a sole proprietorship:] I am the sole proprietor or authorized representative of [Name of Bidder] with office address at [address of Bidder];

[If a partnership, corporation, cooperative, or joint venture:] I am the duly authorized and designated representative of [Name of Bidder] with office address at [address of Bidder];

2. *[Select one, delete the other:]*

[If a sole proprietorship:] As the owner and sole proprietor, or authorized representative of [Name of Bidder], I have full power and authority to do, execute and perform any and all acts necessary to participate, submit the bid, and to sign and execute the ensuing contract for [Name of the Project] of the [Name of the Procuring Entity], as shown in the attached duly notarized Special Power of Attorney;

[If a partnership, corporation, cooperative, or joint venture:] I am granted full power and authority to do, execute and perform any and all acts necessary to participate, submit the bid, and to sign and execute the ensuing contract for [Name of the Project] of the [Name of the Procuring Entity], as shown in the attached [state title of attached document showing proof of authorization (e.g., duly notarized Secretary's Certificate, Board/Partnership Resolution, or Special Power of Attorney, whichever is applicable)];

3. [Name of Bidder] is not "blacklisted" or barred from bidding by the Government of the Philippines or any of its agencies, offices, corporations, or Local Government Units, foreign government/foreign or international financing institution whose blacklisting rules have been recognized by the Government Procurement Policy Board, **by itself or by relation, membership, association, affiliation, or controlling interest with another blacklisted person or entity as defined and provided for in the Uniform Guidelines on Blacklisting:**

4. Each of the documents submitted in satisfaction of the bidding requirements is an authentic copy of the original, complete, and all statements and information provided therein are true and correct;

5. [Name of Bidder] is authorizing the Head of the Procuring Entity or its duly authorized representative(s) to verify all the documents submitted;

6. *[Select one, delete the rest:]*

[If a sole proprietorship:] The owner or sole proprietor is not related to the Head of the Procuring Entity, members of the Bids and Awards Committee (BAC), the Technical



Working Group, and the BAC Secretariat, the head of the Project Management Office or the end-user unit, and the project consultants by consanguinity or affinity up to the third civil degree;

[If a partnership or cooperative:] None of the officers and members of *[Name of Bidder]* is related to the Head of the Procuring Entity, members of the Bids and Awards Committee (BAC), the Technical Working Group, and the BAC Secretariat, the head of the Project Management Office or the end-user unit, and the project consultants by consanguinity or affinity up to the third civil degree;

[If a corporation or joint venture:] None of the officers, directors, and controlling stockholders of *[Name of Bidder]* is related to the Head of the Procuring Entity, members of the Bids and Awards Committee (BAC), the Technical Working Group, and the BAC Secretariat, the head of the Project Management Office or the end-user unit, and the project consultants by consanguinity or affinity up to the third civil degree;

7. *[Name of Bidder]* complies with existing labor laws and standards; and
8. *[Name of Bidder]* is aware of and has undertaken the responsibilities as a Bidder in compliance with the Philippine Bidding Documents, which includes:
 - a. Carefully examining all of the Bidding Documents;
 - b. Acknowledging all conditions, local or otherwise, affecting the implementation of the Contract;
 - c. Making an estimate of the facilities available and needed for the contract to be bid, if any; and
 - d. Inquiring or securing Supplemental/Bid Bulletin(s) issued for the *[Name of the Project]*.
9. *[Name of Bidder]* did not give or pay directly or indirectly, any commission, amount, fee, or any form of consideration, pecuniary or otherwise, to any person or official, personnel or representative of the government in relation to any procurement project or activity.
10. **In case advance payment was made or given, failure to perform or deliver any of the obligations and undertakings in the contract shall be sufficient grounds to constitute criminal liability for Swindling (Estafa) or the commission of fraud with unfaithfulness or abuse of confidence through misappropriating or converting any payment received by a person or entity under an obligation involving the duty to deliver certain goods or services, to the prejudice of the public and the government of the Philippines pursuant to Article 315 of Act No. 3815 s. 1930, as amended, or the Revised Penal Code.**

IN WITNESS WHEREOF, I have hereunto set my hand this ___ day of _____, 20__ at _____, Philippines.

[Insert NAME OF BIDDER OR ITS AUTHORIZED REPRESENTATIVE]

[Insert signatory's legal capacity]
Affiant

[Iurat]

[Format shall be based on the latest Rules on Notarial Practice]

GPPB Resolution No. 16-2020, dated 16 September 2020



Republic of the Philippines
DEPARTMENT OF AGRICULTURE
 Regional Field Office No. 5
 San Agustin, Pili, Camarines Sur

Project Title: REPAIR AND IMPROVEMENT OF MCLD WATER SYSTEM Classification: Agricultural Facility
 Project Location: Brgy. Asid, Masbate City, Masbate Number of Unit: 1.0
 Appropriation: **Php350,000.00** Net Length:
 Source of fund : Project Duration : 15 days
 Subject: **BILL OF QUANTITIES AND COST PROPOSAL** Starting Date: upon receipt of NTP

Scope of Work: -Labor and Materials for the Improvement of Water System Facility
 -Installation of Metal Frame Structure for Elevated Water Tank / Reservoir

MINIMUM EQUIPMENT REQUIREMENT			TECHNICAL PERSONNEL REQUIRED			
Description	No.	Description	Description	No.	Description	
Welding Machine	1	300 Amp, Gas Driven	Foreman	1		
Service Truck	1	2 - 5 Mt, All Model				
Portable Grinding Machine	1	4" dia. Disc				
Cut Off Saw	1	12" dia. Disc				
Minor Tools	enough					
ITEM NO.	DESCRIPTION		QUANTITY	UNIT	UNIT COST (Ps)	AMOUNT (Ps)
PART I	OTHER GENERAL REQUIREMENTS					
I.1	Project Billboard/Signboard		1.00	e.a.		
I.2	Occupational Safety and Health Program		1.00	L.S.		
			Sub-Total			
PART II	ELECTRICAL WORKS					
SPL1	Electrical Protections and Fixtures		1.00	L.S.		
			Sub-Total			
PART III	WATER TANK STORAGE					
102	Common Soil Excavation		6.00	cu.m.		
100(2)	Structural BackFill/Backfilling		3.00	cu.m.		
201	Aggregate Sub Base Course (Gravel Fill)		0.50	cu.m.		
405(1)	Concrete Class "A" w/ Forms (Pedestal)		0.50	cu.m.		
405(2)	Concrete Class "A" w/out Forms (Pedestal Footing)		1.20	cu.m.		
404	Reinforcing Steel Bar		120.00	kgs.		
SPL2	Bladder Type Pressurizes Tank		1.00	e.a.		
SPL3	2,000 Liters P.E. Tank		1.00	e.a.		
SPL4	Water Tank Framing Structure, Flatform, and Support		1.00	L.S.		
			Sub-Total			
PART IV						
SPL5	Water Piping and Fixture		100.00	m		
			Sub-Total			
TOTAL PROJECT COST					~	350,000.00

Note: All Taxes, contractors profit and hauling costs are included in unit cost per item

 NAME AND SIGNATURE OF BIDDER



REPUBLIC OF THE PHILIPPINES
DEPARTMENT OF AGRICULTURE
REGIONAL FIELD OFFICE NO.5
SAN AGUSTIN, PILI, CAMARINES SUR.

PROJECT TITLE:

**REPAIR AND IMPROVEMENT
OF MCLD WATER SYSTEM
FACILITY**

LOCATION: BRGY. ASID, MASBATE CITY, MASBATE

PREPARED BY:
RAED OFFICE

RAED-EPDSS-009
Effectivity Date: February 02, 2022

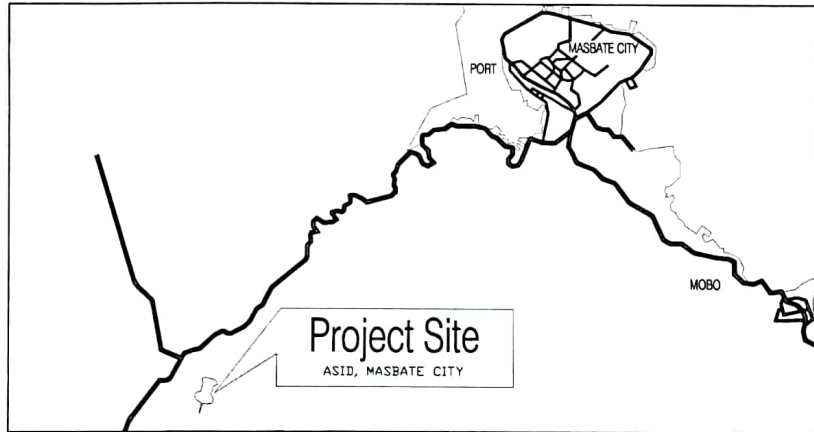

LOCATION MAP

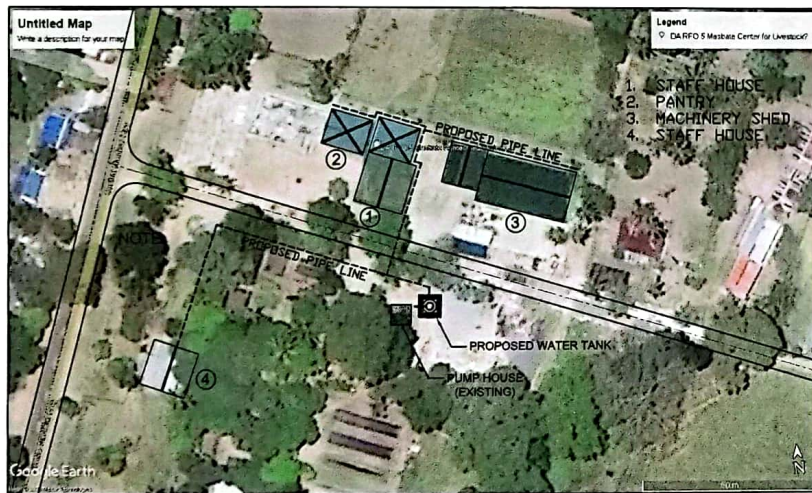

PIPE LINE LAYOUT

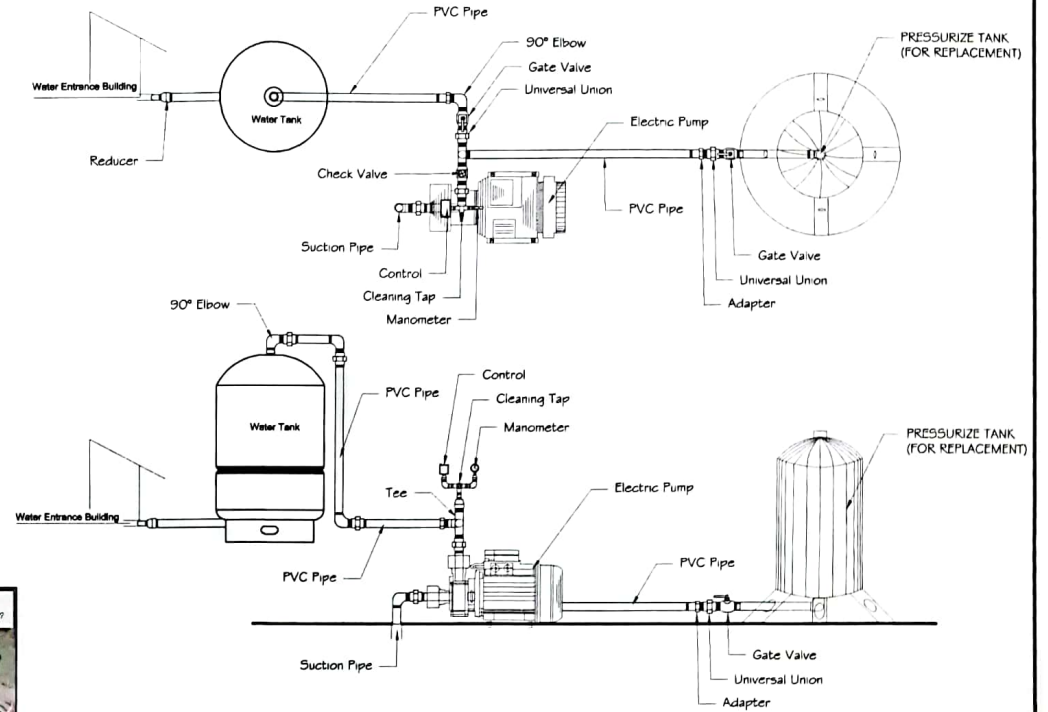

NOTE:

1. EXISTING ELECTRIC PUMP
2. FOR REPLACEMENT OF PRESSURIZED TANK
3. FOR REPLACEMENT AND IMPROVEMENT OF FITTINGS
4. INSTALLATION OF WATER TANK

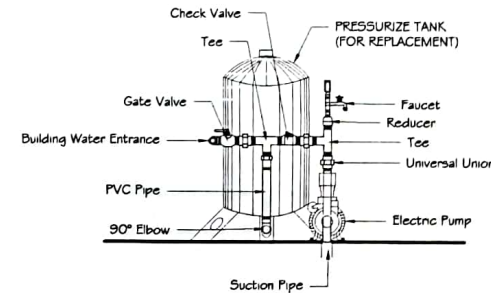

HYDRO-PNEUMATIC SYSTEM

RAED-EPDSS-009
Effectivity Date: February 02, 2022

	Prepared by:	Checked by:	Reviewed by:	Submitted by:	Recommending Approval:	Approved by:	Name of Project:	CAD by:
	BELL JOSEPH D. BONITO CAD-Insp	ARTHUR B. MIRA Engineer II	LUISITO R. BALTAZAR EPDSS Head	JERRY A. EBOÑA QC - Chief RAED	LUZ R. MARCELINO RTD, Sr. Operations	RODEL P. TORNILHA, MABE Regional Executive Director	Repair and Improvement of MCLD Water System Facility	File: 001
							Location:	DATE:
							Brgy. Asid, Masbate City, Masbate	12-0200
						Sheet Content:	Sheet No.:	
						AS SHOWN		

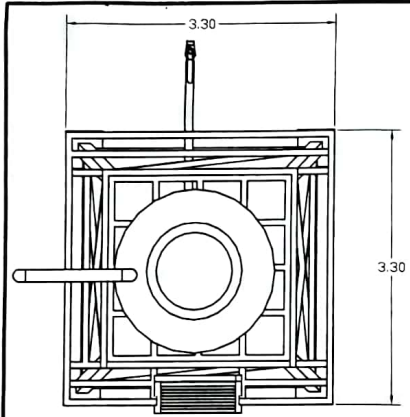

PLAN
SCALE 1: 40 MTS.

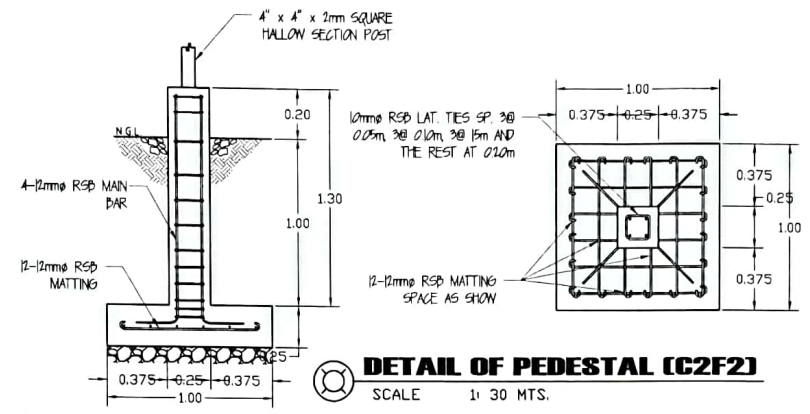

DETAIL OF PEDESTAL (C2F2)
SCALE 1: 30 MTS.

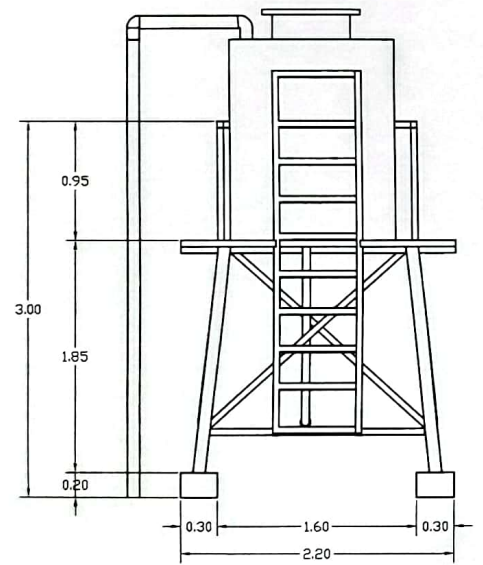

FRONT ELEVATION
SCALE 1: 40 MTS.

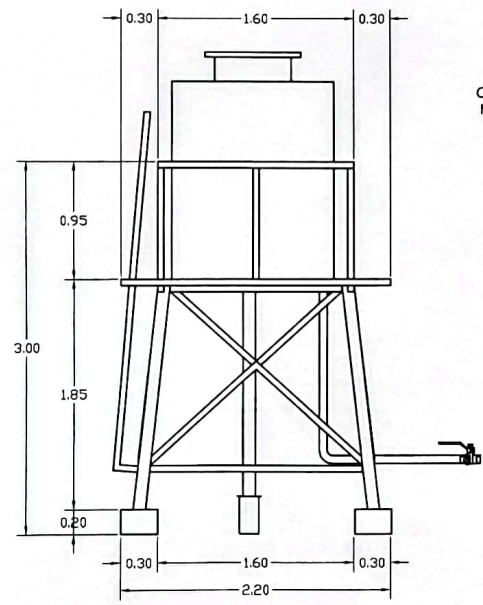

SIDE ELEVATION
SCALE 1: 40 MTS.

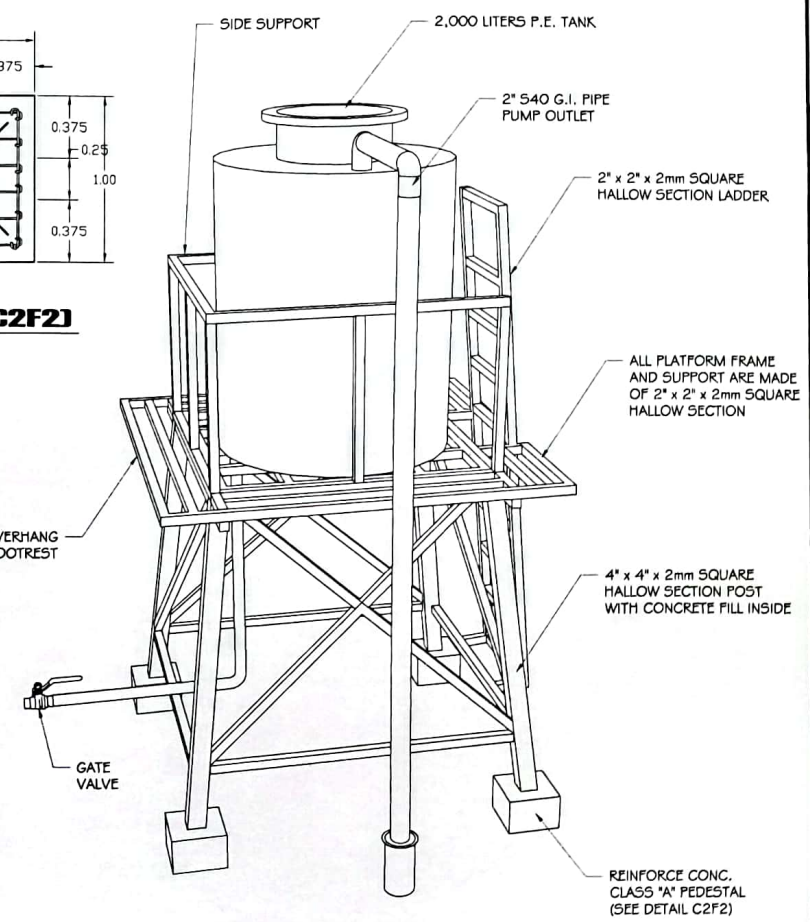

ISOMETRIC VIEW
NOT TO SCALE

RAED-EPDSS-009
Effectivity Date: February 02, 2022

<p>REPUBLIC OF THE PHILIPPINES DEPARTMENT OF AGRICULTURE REGIONAL FIELD OFFICE NO. 5 SAN AGUSTIN, PILI, CAMARINES SUR</p>	Prepared by:	Checked by:	Reviewed by:	Submitted by:	Recommending Approval:	Approved by:	Name of Project:	CAD by:	
	<i>[Signature]</i> BELL JOSEPH D. BONITO CAD-Insp	<i>[Signature]</i> ARTHUR B. MIRA Engineer II	<i>[Signature]</i> LUISITO R. BALAZAR EPDSS Insp	<i>[Signature]</i> JERRY A. EBOÑA OIC - Chief RAED	<i>[Signature]</i> LUZ R. MARCELINO RTD. for Operations	<i>[Signature]</i> RODEL P. TORNILLO, MABE Regional Executive Director		Repair and Improvement of MCLD Water System Facility	File No:
								Brgy. Asid, Masbate City, Masbate	DATE:
								AS SHOWN	13-0200
							Street Contact:	Sheet No.:	